

REF 16100601

COMPETITOR BULLETIN - SPORTING REGULATORY AMENDMENTS

Dear Competitor/Entrant,

This formal bulletin is to alert you to the following additions/amendments to the UAE Rotax MAX Challenge 2016-17 Sporting Regulations ahead of Round 1.

The below text has been amended under **Article 12B (Penalty Catalogue)**:

B. JUMP START

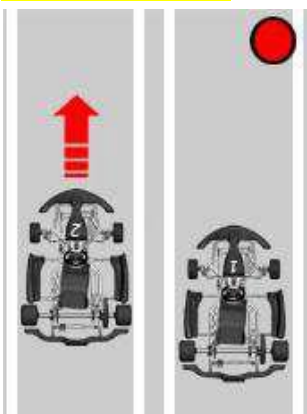

A **JUMP-START** is declared by a Judge Of Fact when a kart either (1) has accelerated prematurely before crossing the yellow acceleration line and/or before the red race start lights have been switched off, and/or (2) is ahead of its prescribed position at the time the start signal is given *(as depicted by kart number 2 in the left illustration)*.

Penalty: 10 seconds

Note: The penalty may be applied against the offending driver(s) even if the start is aborted and declared a "FALSE START". This is at the discretion of the Clerk of the Course.

If one driver is guilty of causing multiple false starts then the race direction may apply a penalty at their discretion which could be relegation to the back or a time penalty as specified above.

Article 12M (Penalty Catalogue) has been added:

M. FRONT FAIRING MOUNTING KIT

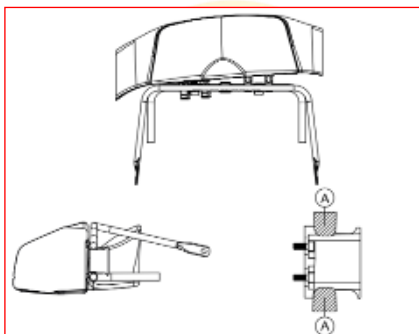

THE FRONT FAIRING IS NOT IN AN ACCEPTABLE POSITION IF ANY PART OF THE TUBES OF THE FRONT BUMPER ARE IN THE AREA 'A'.

Where the CIK-homologated detachable front fairing mounting kit is used, it must at all times during live sessions be fitted and maintained in the correct position in accordance with Competitor Bulletin REF 16100501.

TYPE A - DETACHMENT - A Judge of Fact reports the front fairing of a kart to be in an unacceptable position as defined by Bulletin REF 16100501 *(and shown in the left illustration)*

Penalty (Race): 10 seconds

Penalty (Qualifying): Deletion of fastest lap

Note: The above penalty is mandatory and indisputable for front fairing non-compliance only. Drivers may be referred to the Stewards for offences that gave rise to the non-compliance.

TYPE B - ILLEGAL REPLACEMENT - A competitor replaces/refits/resets the front fairing to an 'acceptable' position in advance of formal inspection in Parc Fermé (in an attempt to avoid the sanction detailed in TYPE A above).

Penalty: Exclusion

The above changes are reflected in version 05.10.16 of the Sporting Regulations 2016-17 (which have replaced version 20.09.16 and are now available for download).

Yours sincerely,



Guy Sheffield
Al Ain Raceway

